

EUROCRAFT INDUSTRIES INC.

76MD IN-SWING CASEMENT/TILT & TURN WINDOW (IMPACT) (HVHZ)



7905 NW 77TH AVE
MEDLEY, FL 33166
PH: (305) 888-5718 FX: (305) 220-5073

GENERAL NOTES:

- THE PRODUCT SHOWN HEREIN IS DESIGNED AND MANUFACTURED TO COMPLY WITH THE CURRENT EDITION FLORIDA BUILDING CODE (FBC), INCLUDING HVHZ AND HAS BEEN EVALUATED ACCORDING TO THE FOLLOWING:
 - TAS 201-94
 - TAS 202-94
 - TAS 203-94
- ADEQUACY OF THE EXISTING STRUCTURAL CONCRETE/MASONRY, 2X FRAMING, AND METAL FRAMING AS A MAIN WIND FORCE RESISTING SYSTEM CAPABLE OF WITHSTANDING AND TRANSFERRING APPLIED PRODUCT LOADS TO THE FOUNDATION IS THE RESPONSIBILITY OF THE ENGINEER OR ARCHITECT OF RECORD FOR THE PROJECT OF INSTALLATION.
- 1X AND 2X BUCKS (WHEN USED) SHALL BE DESIGNED AND ANCHORED TO PROPERLY TRANSFER ALL LOADS TO THE STRUCTURE. BUCK DESIGN AND INSTALLATION IS THE RESPONSIBILITY OF THE ENGINEER OR ARCHITECT OF RECORD FOR THE PROJECT OF INSTALLATION.
- INSTALL INDIVIDUAL INSTALLATION ANCHORS WITHIN A TOLERANCE OF ±1/4 INCH OF THE DEPICTED LOCATION IN THE ANCHOR LAYOUT DETAIL (I.E., WITHOUT CONSIDERATION OF TOLERANCES). TOLERANCES ARE NOT CUMULATIVE FROM ONE INSTALLATION ANCHOR TO THE NEXT.
- THE INSTALLATION DETAILS DESCRIBED HEREIN ARE GENERIC AND MAY NOT REFLECT ACTUAL CONDITIONS FOR A SPECIFIC SITE. IF SITE CONDITIONS CAUSE INSTALLATION TO DEVIATE FROM THE REQUIREMENTS DETAILED HEREIN, A LICENSED ENGINEER OR ARCHITECT SHALL PREPARE SITE SPECIFIC DOCUMENTS FOR USE WITH THIS DOCUMENT IN NON-HVHZ AREAS. IN HVHZ AREAS, ONE TIME PRODUCT APPROVAL TO BE OBTAINED FROM MIAMI-DADE RER OR AHJ.
- APPROVED IMPACT PROTECTIVE SYSTEM **IS NOT REQUIRED** ON THIS PRODUCT IN AREAS REQUIRING IMPACT RESISTANCE.
- WINDOW FRAME MATERIAL: RIGID PVC
- GLASS MEETS THE REQUIREMENTS OF ASTM E 1300 GLASS CHARTS. SEE SHEET 1 FOR GLAZING DETAILS.

- NOTE:**
- GLASS TYPE THICKNESS SHALL COMPLY WITH ASTM E-1300 GLASS CHART REQUIREMENTS.
 - ALL GLAZING CONFIGURATIONS SHALL COMPLY WITH SAFETY GLAZING REQUIREMENTS OUTLINED IN CURRENT FBC
 - SETTING BLOCK SHOULD BE 70-90 DUROMETER AS PER CH 24 OF THE CURRENT FBC.
 - GLASS LITES THAT EXCEED 36" IN WIDTH SHALL USE SETTING BLOCKS AT 1/4 SPAN FROM CORNERS.

MAX OVERALL SIZE		CONFIG.	DESIGN PRESSURE	MISSILE IMPACT RATING
WIDTH	HEIGHT			
48"	84"	X	+/- 120 PSF	LMI
96"	84"	XX	+/- 120 PSF	LMI

TABLE OF CONTENTS		
SHEET	REVISION	SHEET DESCRIPTION
1	-	GENERAL NOTES AND GLAZING DETAILS
2	-	ELEVATIONS & ANCHOR LAYOUTS
3	-	ELEVATIONS & ANCHOR LAYOUTS
4	-	VERTICAL & HORIZONTAL SECTIONS
5	-	VERTICAL & HORIZONTAL SECTIONS
6	-	INSTALLATION NOTES ANCHOR DETAILS
7	-	BILL OF MATERIALS
8	-	MULTIPOINT HARDWARE

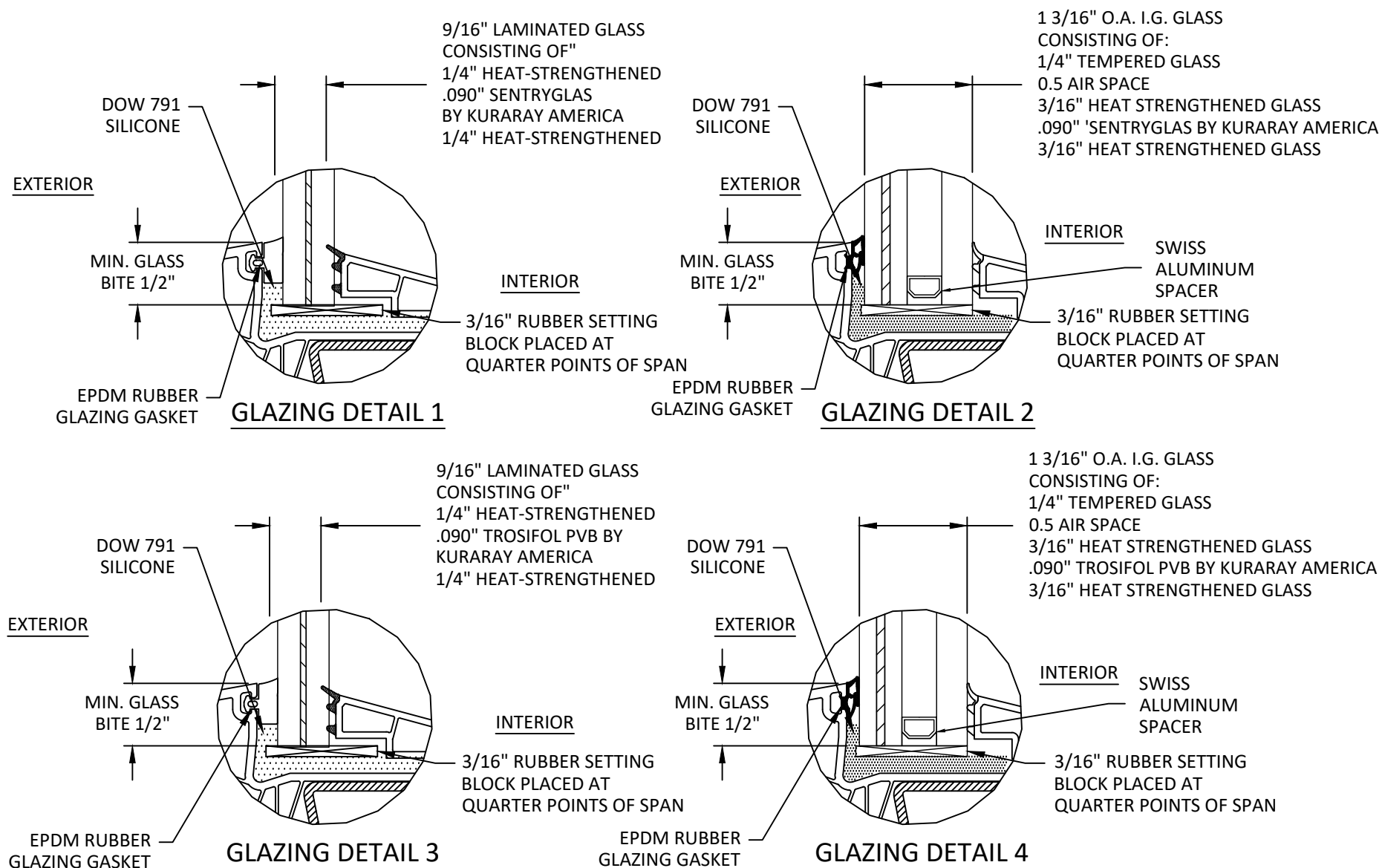

TITLE: 76MD IN-SWING CASEMENT/TILT & TURN WINDOW (IMPACT) (HVHZ)
GENERAL NOTES AND GLAZING DETAILS

PREPARED BY: BUILDING DROPS, INC.
398 E. DANIA BEACH BLVD., STE. 338
DANIA BEACH, FL 33004
PH: (954) 399-8478
FAX: (954) 744-4738
WEB: www.buildingdrops.com

REMARKS	BY	DATE

THE INSTALLATION DETAILS DESCRIBED HEREIN ARE GENERIC AND MAY NOT REFLECT ACTUAL CONDITIONS FOR A SPECIFIC SITE. IF SITE CONDITIONS CAUSE INSTALLATION TO DEVIATE FROM THE REQUIREMENTS DETAILED HEREIN, A LICENSED ENGINEER OR ARCHITECT SHALL PREPARE SITE SPECIFIC DOCUMENTS FOR USE WITH THIS DOCUMENT

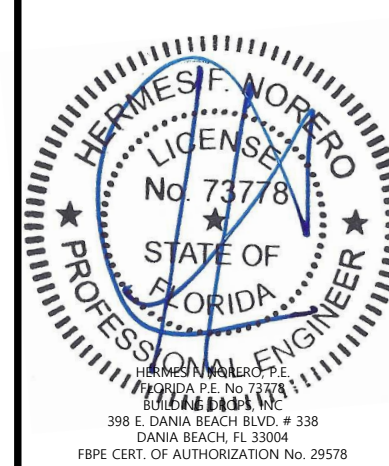

FL#:	FL29689	
DATE:	06.09.19	
DWG. BY:	EG	CHK. BY: HFN
SCALE:	NTS	
DWG. #:	ECI013	
SHEET:	1 OF 8	

12/18/2020 9:11 AM
s:\projects\eurocraft_industries inc\cc-20-0916-fbc code change (ver. 7)12-revision due to alum. anchors\129689\dwg\eci013 - in-swing cs.dwg

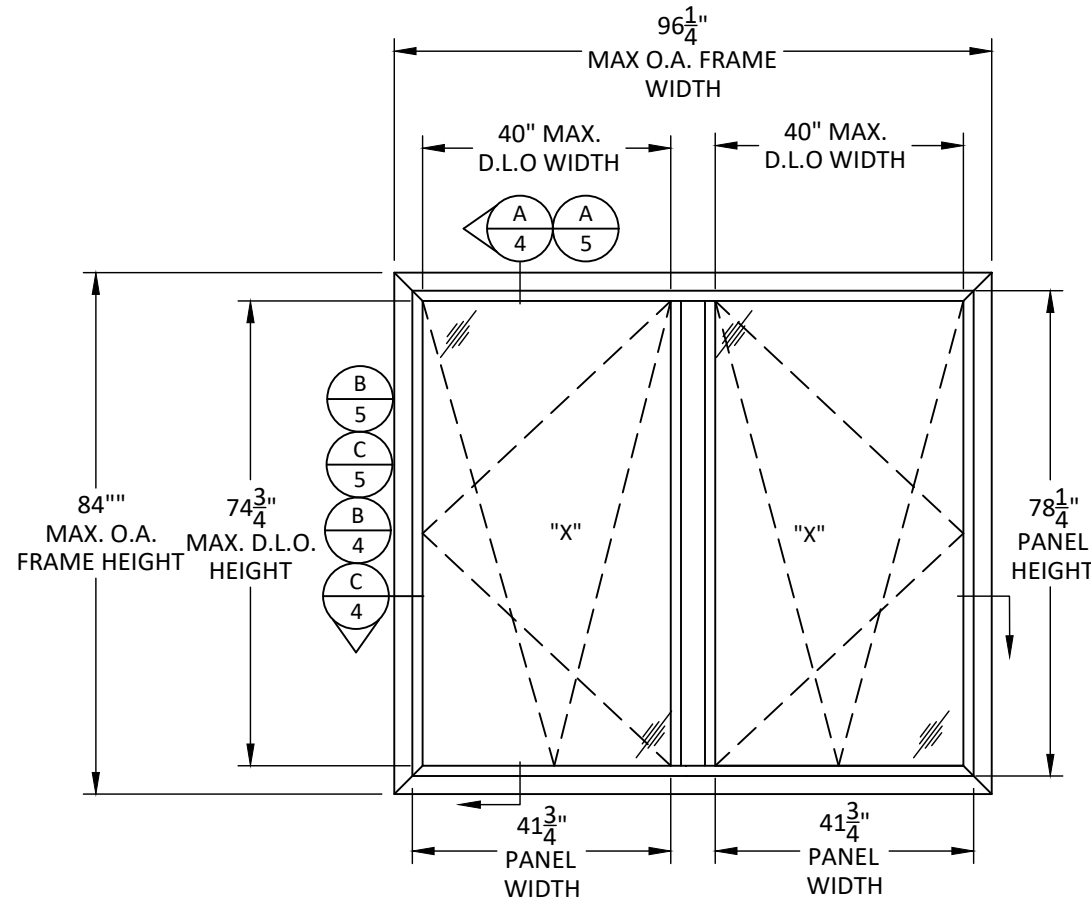

ELEVATION
INSWING OR OUTSWING

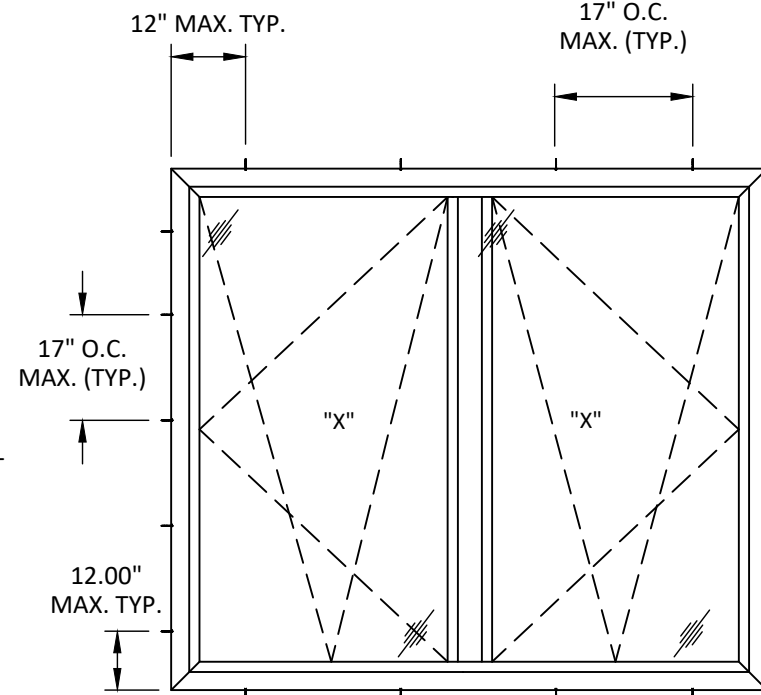

ANCHOR LAYOUT
THROUGH FRAME

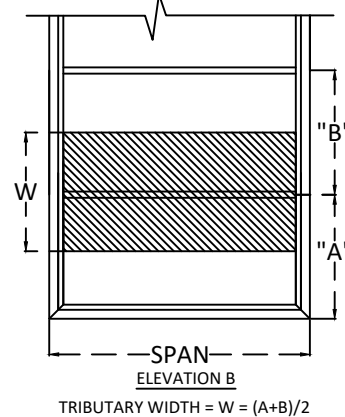
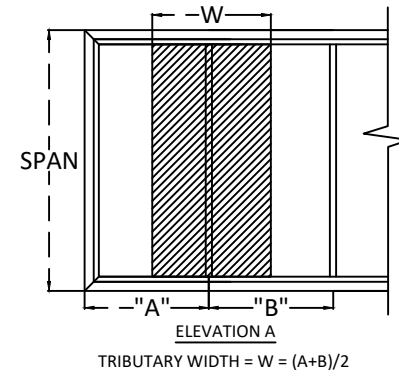

QUALIFIED CONFIGURATIONS

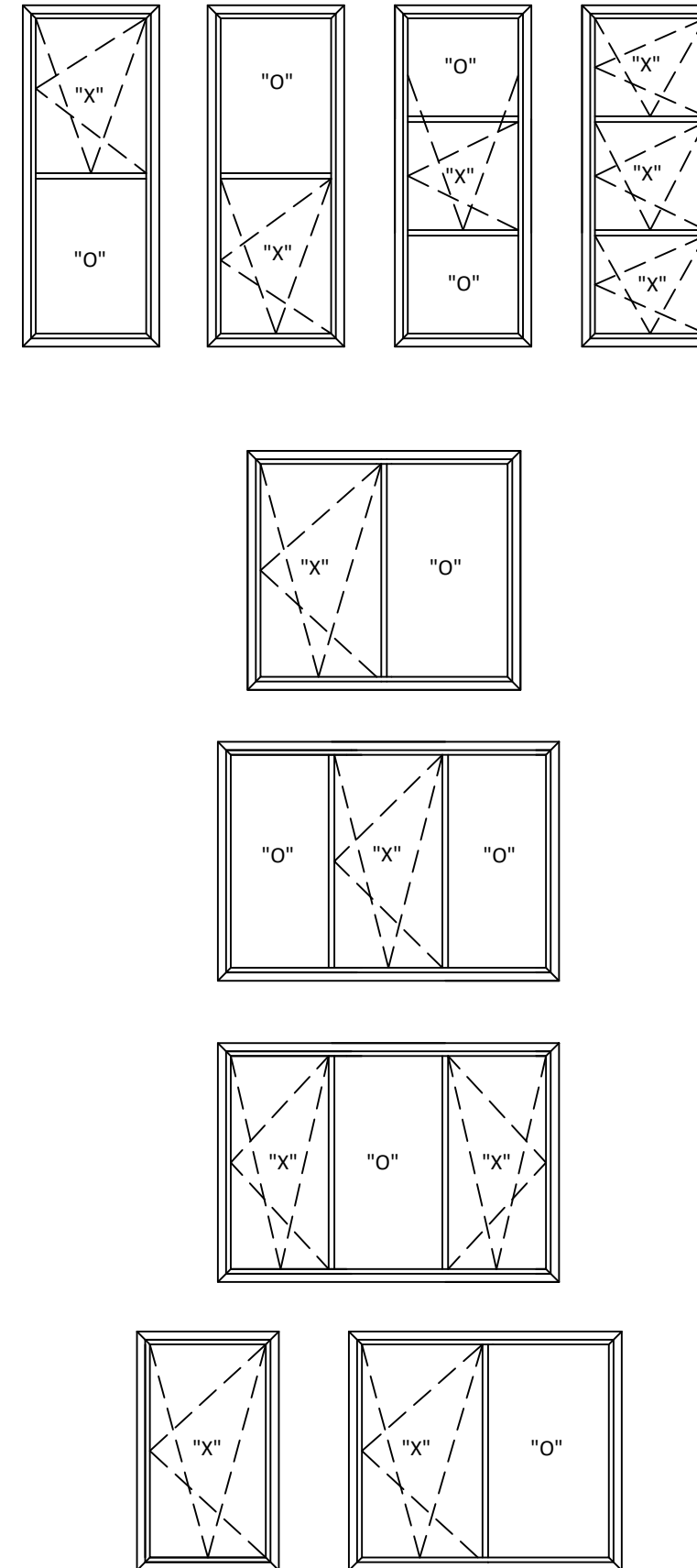

DESIGN PRESSURE TABLE (psf) - CASEMENT/T&T WINDOW WITH GLAZING DETAILS G1-G4								
		PANEL WIDTH (INCHES)						
		24	30	36	42	48	54	66
PANEL HEIGHT (INCHES)	60	120.0	120.0	120.0	120.0	120.0	106.7	105.6
	66	120.0	120.0	120.0	120.0	120.0	106.7	-
	72	120.0	120.0	120.0	120.0	120.0	106.7	-
	78	120.0	120.0	120.0	120.0	120.0	-	-
	84	120.0	120.0	120.0	120.0	120.0	-	-
	90	120.0	120.0	120.0	120.0	-	-	-
	96	120.0	120.0	120.0	120.0	-	-	-
	102	120.0	120.0	120.0	-	-	-	-
	108	120.0	120.0	120.0	-	-	-	-
	114	120.0	120.0	-	-	-	-	-
120	120.0	120.0	-	-	-	-	-	

NOTE:
TABLE APPLIES TO ITEMS (5) AND (10)

7905 NW 77TH AVE
MEDLEY, FL 33166
PH: (305) 888-5718 FX: (305) 220-5073

ELEVATIONS AND ANCHOR LAYOUTS

PREPARED BY:
BUILDING DROPS, INC.
398 E. DANIA BEACH BLVD., STE. 338
DANIA BEACH, FL 33004
PH: (954) 399-8478
FAX: (954) 744-4738
WEB: www.buildingdrops.com

REMARKS	BY	DATE

THE INSTALLATION DETAILS DESCRIBED HEREIN ARE GENERIC AND MAY NOT REFLECT ACTUAL CONDITIONS FOR A SPECIFIC SITE. IF SITE CONDITIONS CAUSE INSTALLATION TO DEVIATE FROM THE REQUIREMENTS DETAILED HEREIN, A LICENSED ENGINEER OR ARCHITECT SHALL PREPARE SITE SPECIFIC DOCUMENTS FOR USE WITH THIS DOCUMENT

HERMES J. MORERO, P.E.
FLORIDA P.E. No. 73778
BUILDING DROPS, INC.
398 E. DANIA BEACH BLVD. # 338
DANIA BEACH, FL 33004
FBPE CERT. OF AUTHORIZATION No. 29578

FL#: **FL29689**

DATE: **06.09.19**

DWG. BY: EG	CHK. BY: HFN
-----------------------	------------------------

SCALE: **NTS**

DWG. #: **ECI013**

SHEET:
2
OF 8

12/18/2020 9:11 AM
 s:\projects\eurocraft_industries\inc\20-0916-fbc code change (ver. 7)12-revision due to alum. anchors\129689\dwg\eci013 - in-swing cs.dwg

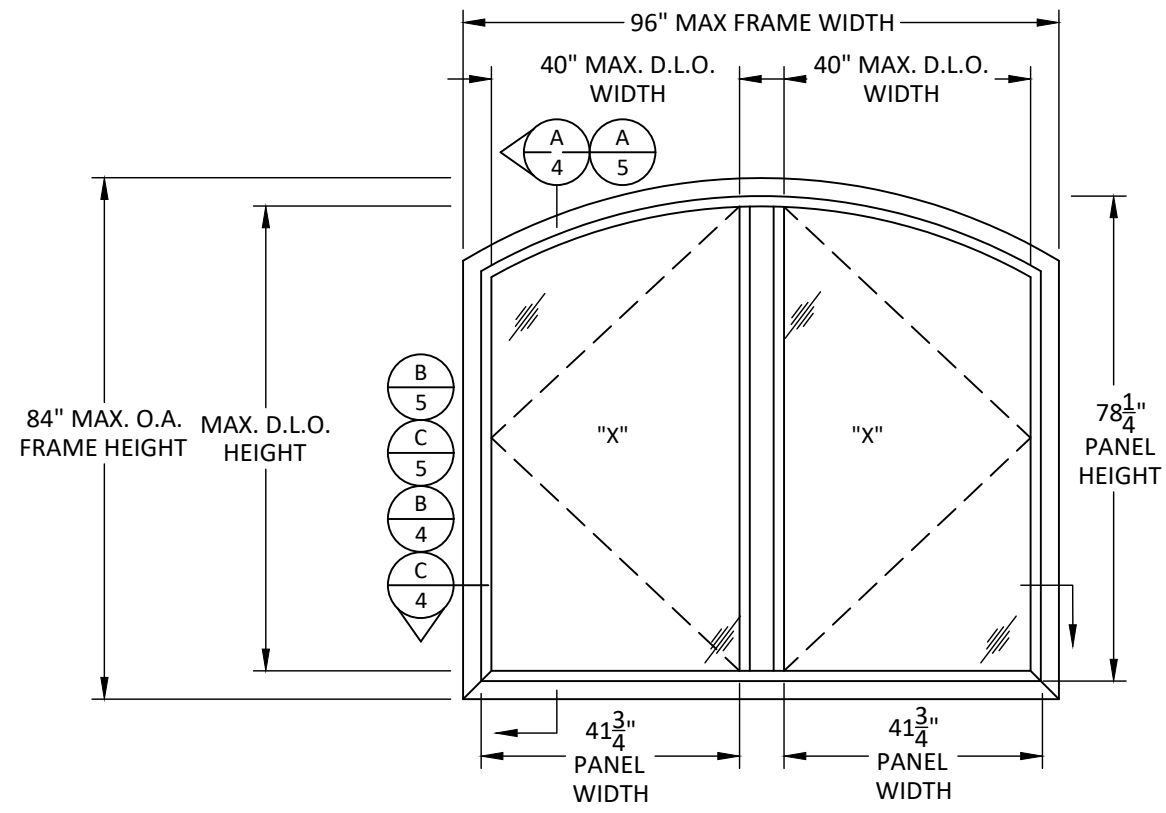

ELEVATION
INSWING OR OUTSWING

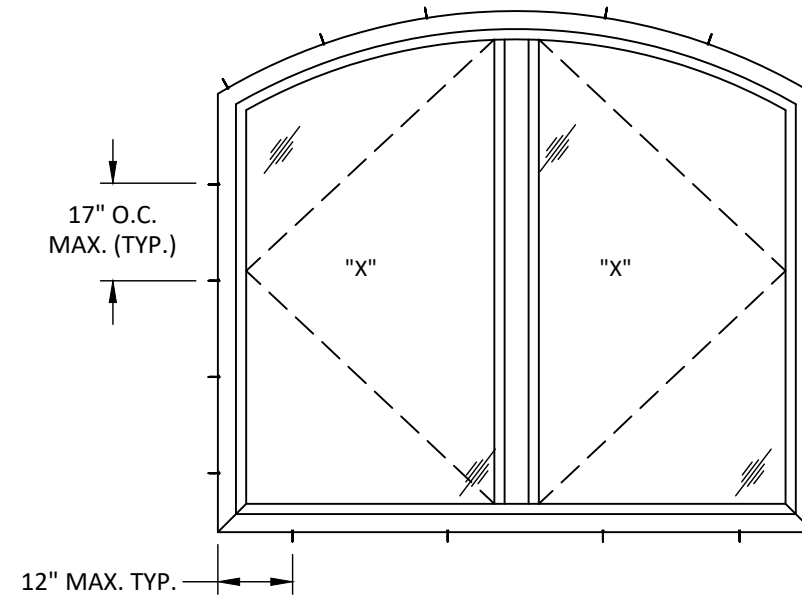

ANCHOR LAYOUT
THROUGH FRAME

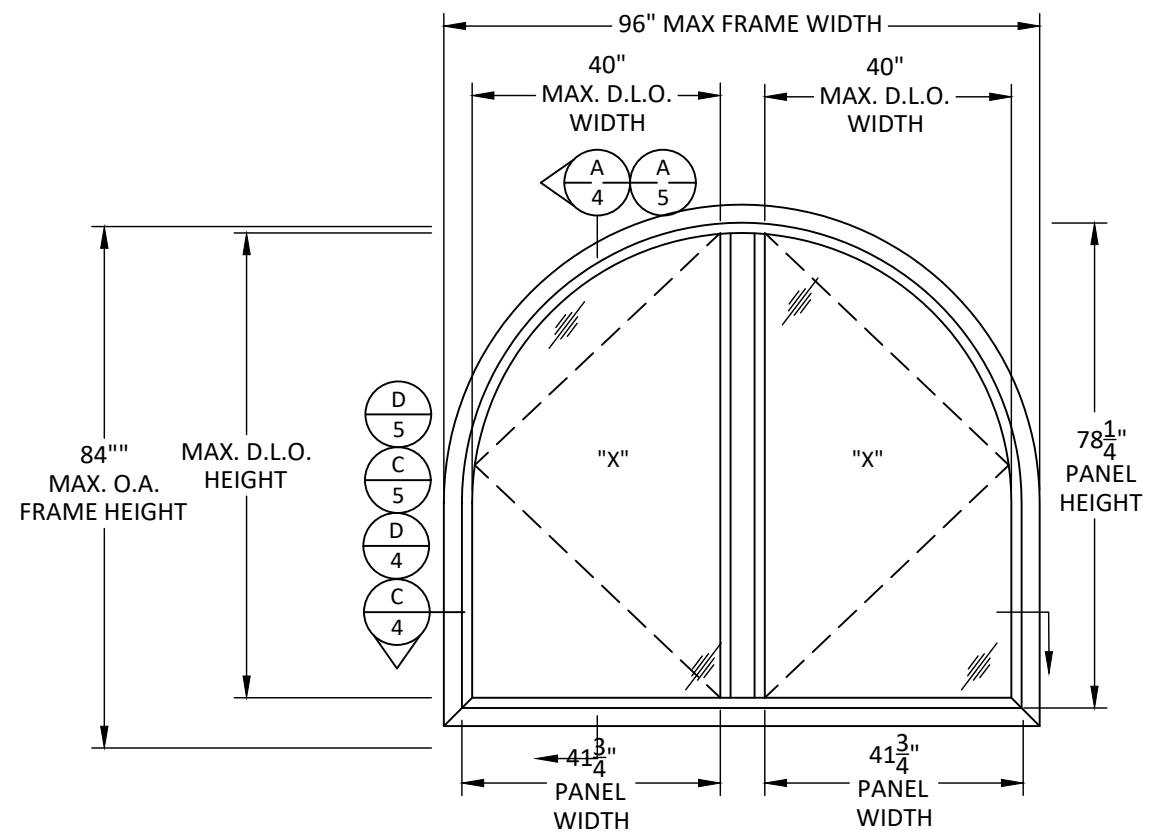

ELEVATION
INSWING OR OUTSWING

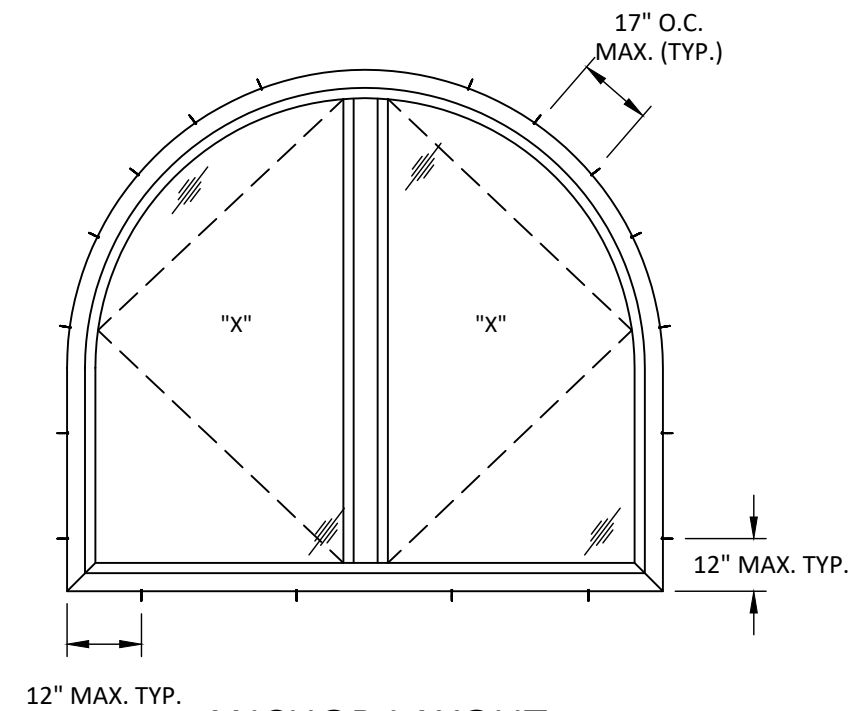

ANCHOR LAYOUT
THROUGH FRAME

7905 NW 77TH AVE
 MEDLEY, FL 33166
 PH: (305) 888-5718 FX: (305) 220-5073

TITLE: 76MD IN-SWING CASEMENT/TILT & TURN WINDOW (IMPACT) (HVHZ)

ELEVATIONS AND ANCHOR LAYOUTS

PREPARED BY: BUILDING DROPS, INC.
 398 E. DANIA BEACH BLVD., STE. 338
 DANIA BEACH, FL 33004
 PH: (954) 399-8478
 FAX: (954) 744-4738
 WEB: www.buildingdrops.com

REMARKS	BY	DATE

THE INSTALLATION DETAILS DESCRIBED HEREIN ARE GENERIC AND MAY NOT REFLECT ACTUAL CONDITIONS FOR A SPECIFIC SITE. IF SITE CONDITIONS CAUSE INSTALLATION TO DEVIATE FROM THE REQUIREMENTS DETAILED HEREIN, A LICENSED ENGINEER OR ARCHITECT SHALL PREPARE SITE SPECIFIC DOCUMENTS FOR USE WITH THIS DOCUMENT

HERMES F. MORERO, P.E.
 FLORIDA P.E. No. 73778
 BUILDING DROPS, INC.
 398 E. DANIA BEACH BLVD. # 338
 DANIA BEACH, FL 33004
 FBPE CERT. OF AUTHORIZATION No. 29578

FL#:	FL29689
DATE:	06.09.19
DWG. BY:	EG
CHK. BY:	HFN
SCALE:	NTS
DWG. #:	ECI013

SHEET: **3**
 OF 8

s:\projects\eurocraft_industries inc\cc-20-0916-fbc code change (ver. 7)12-revision due to alum. anchors\129689\dwg\eci013 - in-swing cs.dwg 12/18/2020 9:11 AM

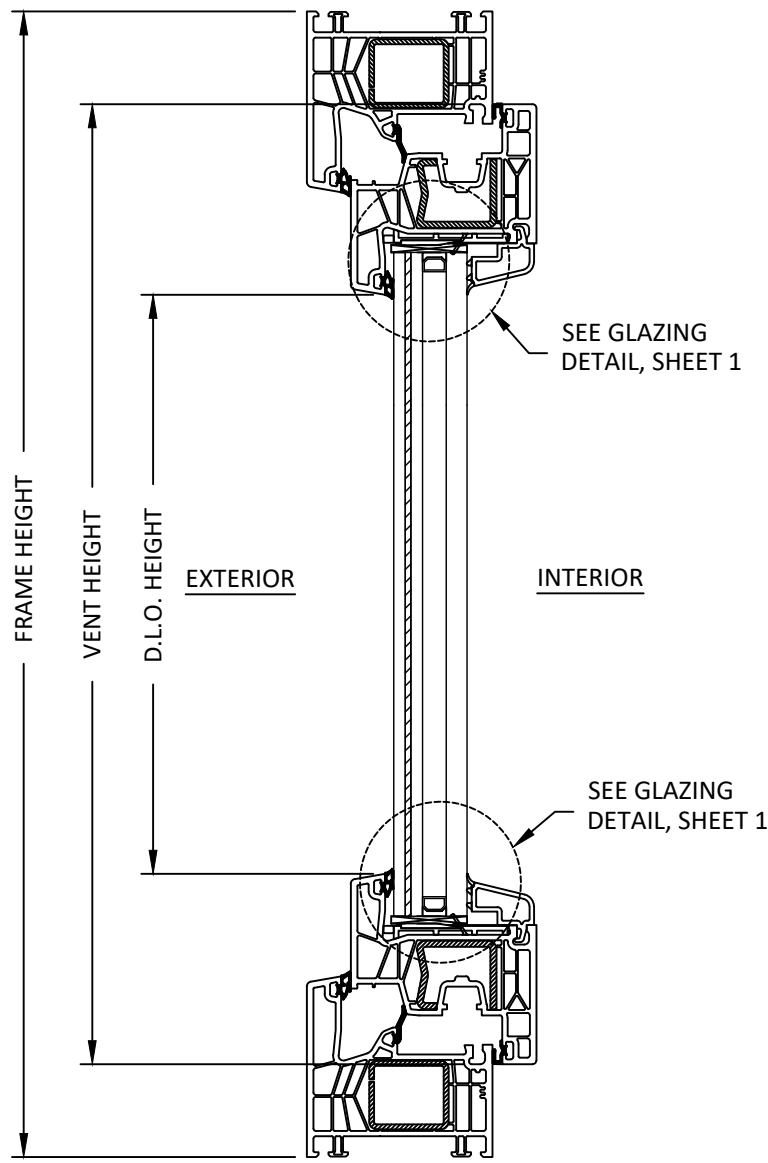

A
4 **VERTICAL SECTION**
OPERABLE WINDOW

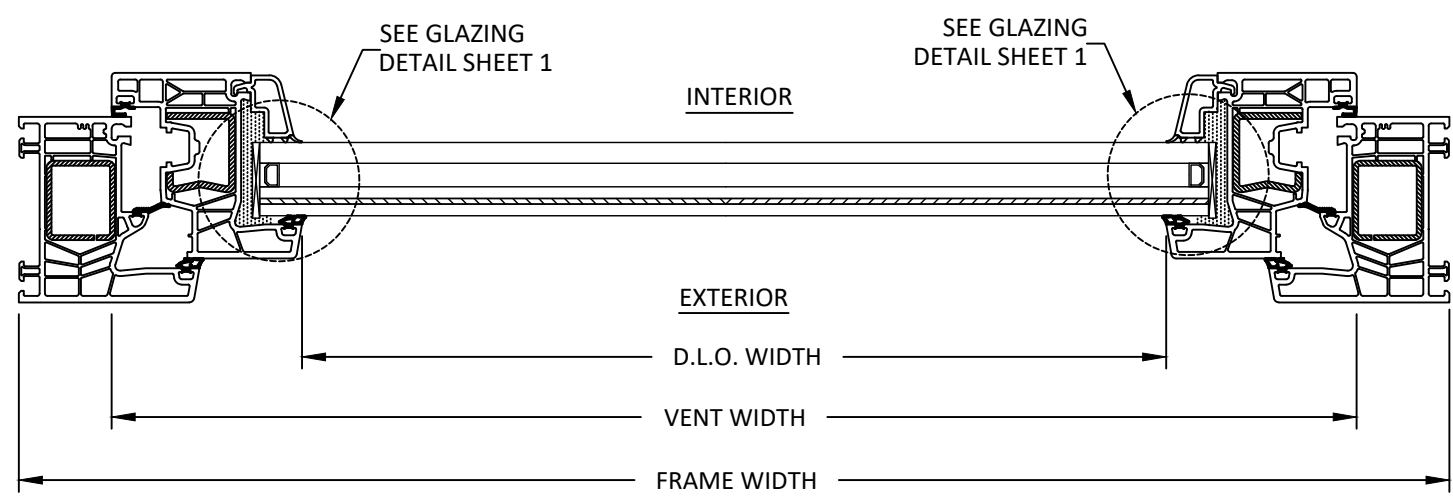

B
4 **HORIZONTAL SECTION**
OPERABLE WINDOW

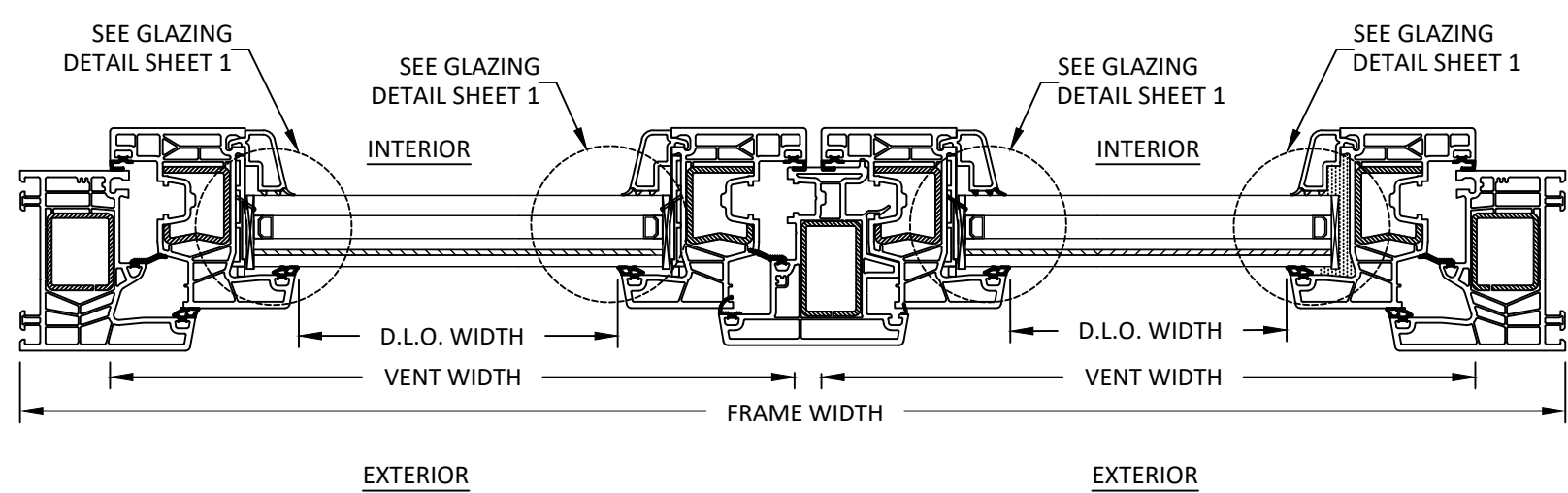

C
4 **HORIZONTAL SECTION**
OPERABLE TWIN WINDOW



7905 NW 77TH AVE
MEDLEY, FL 33166
PH: (305) 888-5718 FX: (305) 220-5073

TITLE: 76MD IN-SWING CASEMENT/TILT & TURN WINDOW (IMPACT) (HVHZ)
VERTICAL SECTIONS AND HORIZONTAL SECTIONS

PREPARED BY:  BUILDING DROPS, INC.
398 E. DANIA BEACH BLVD., STE. 338
DANIA BEACH, FL 33004
PH: (954) 399-8478
FAX: (954) 744-4738
WEB: www.buildingdrops.com

REMARKS	BY	DATE

THE INSTALLATION DETAILS DESCRIBED HEREIN ARE GENERIC AND MAY NOT REFLECT ACTUAL CONDITIONS FOR A SPECIFIC SITE. IF SITE CONDITIONS CAUSE INSTALLATION TO DEVIATE FROM THE REQUIREMENTS DETAILED HEREIN, A LICENSED ENGINEER OR ARCHITECT SHALL PREPARE SITE SPECIFIC DOCUMENTS FOR USE WITH THIS DOCUMENT

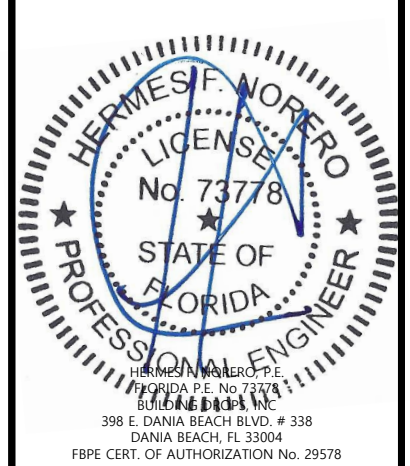

FL#:	FL29689
DATE:	06.09.19
DWG. BY:	EG
CHK. BY:	HFN
SCALE:	NTS
DWG. #:	ECI013
SHEET:	4

12/18/2020 9:11 AM
 s:\projects\eurocraft industries inc\cc-20-0916-fbc code change (ver. 7)\2-revision due to alum. anchors\129689\dwg\eci013 - in-swing cs.dwg

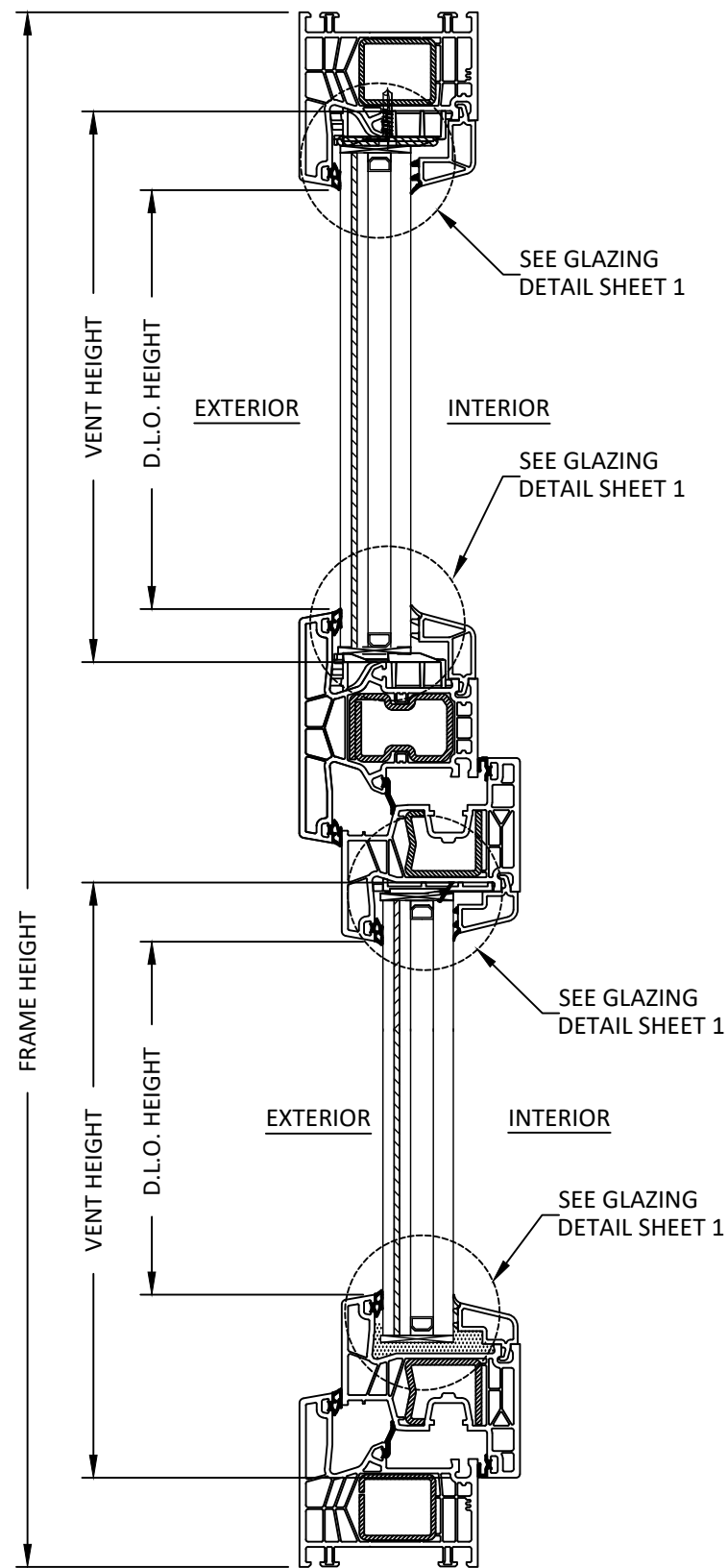

A
5 **VERTICAL SECTION**
OPERABLE FIXED WINDOW

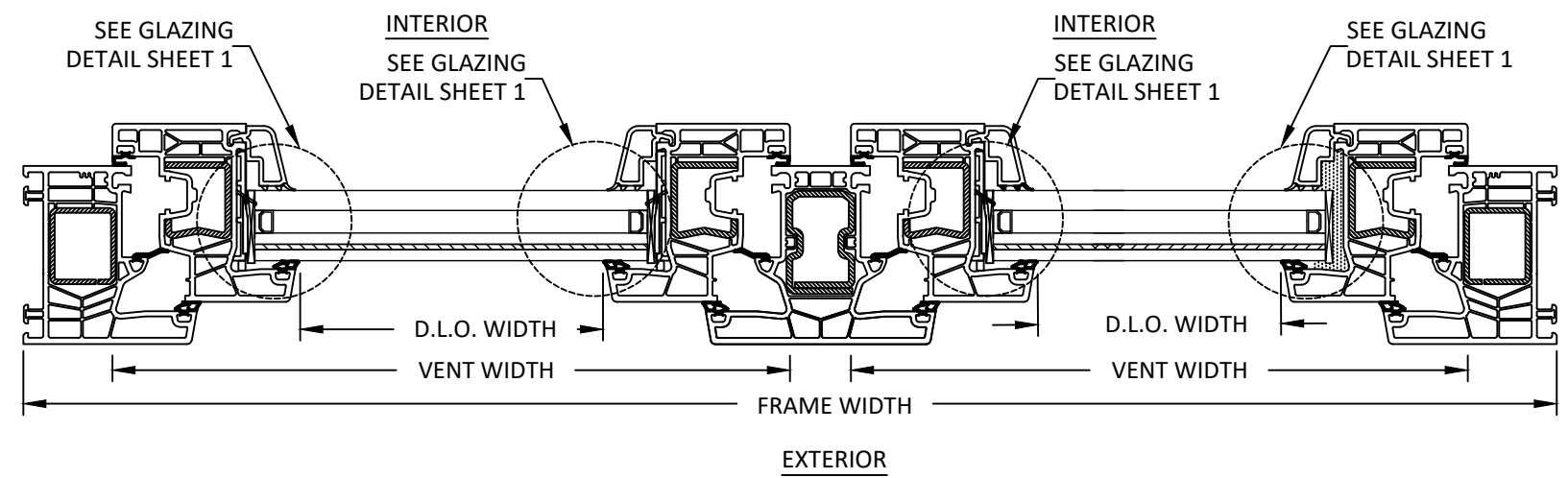

B
5 **HORIZONTAL SECTION**
OPERABLE TWIN WINDOW

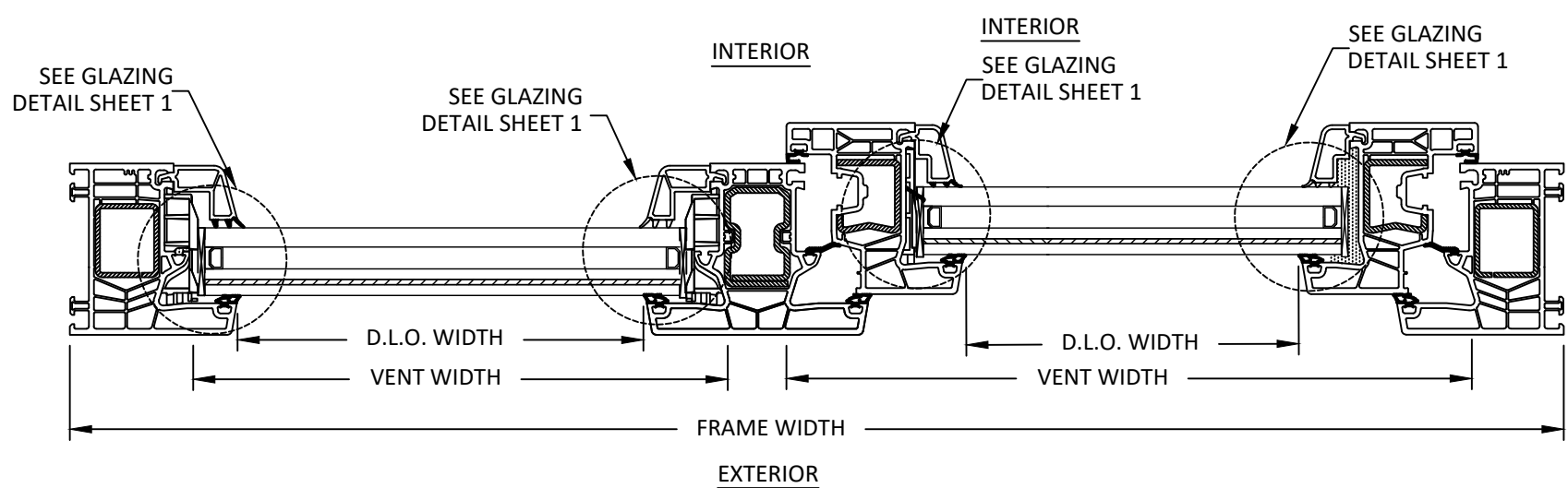

C
5 **HORIZONTAL SECTION**
OPERABLE FIXED WINDOW



7905 NW 77TH AVE
MEDLEY, FL 33166
PH: (305) 888-5718 FX: (305) 220-5073

TITLE:
76MD IN-SWING CASEMENT/TILT
& TURN WINDOW (IMPACT) (HVHZ)

VERTICAL SECTIONS AND HORIZONTAL
SECTIONS

PREPARED BY:
BUILDING DROPS, INC.
398 E. DANIA BEACH BLVD., STE. 338
DANIA BEACH, FL 33004
PH: (954) 399-8478
FAX: (954) 744-4738
WEB: www.buildingdrops.com

REMARKS	BY	DATE

THE INSTALLATION DETAILS DESCRIBED HEREIN ARE GENERIC AND MAY NOT REFLECT ACTUAL CONDITIONS FOR A SPECIFIC SITE. IF SITE CONDITIONS CAUSE INSTALLATION TO DEVIATE FROM THE REQUIREMENTS DETAILED HEREIN, A LICENSED ENGINEER OR ARCHITECT SHALL PREPARE SITE SPECIFIC DOCUMENTS FOR USE WITH THIS DOCUMENT

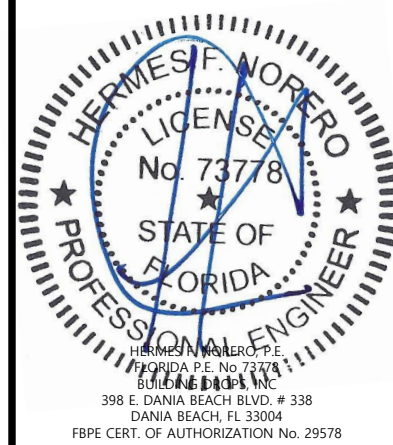

FL#: **FL29689**

DATE: **06.09.19**

DWG. BY: **EG** CHK. BY: **HFN**

SCALE: **NTS**

DWG. #: **ECI013**

SHEET:

5

OF 8

12/18/2020 9:11 AM
 s:\projects\eurocraft_industries\inc\cc-20-0916-fbc code change (ver. 7)\12-revision due to alum. anchors\129689\dwg\eci013 - in-swing cs.dwg

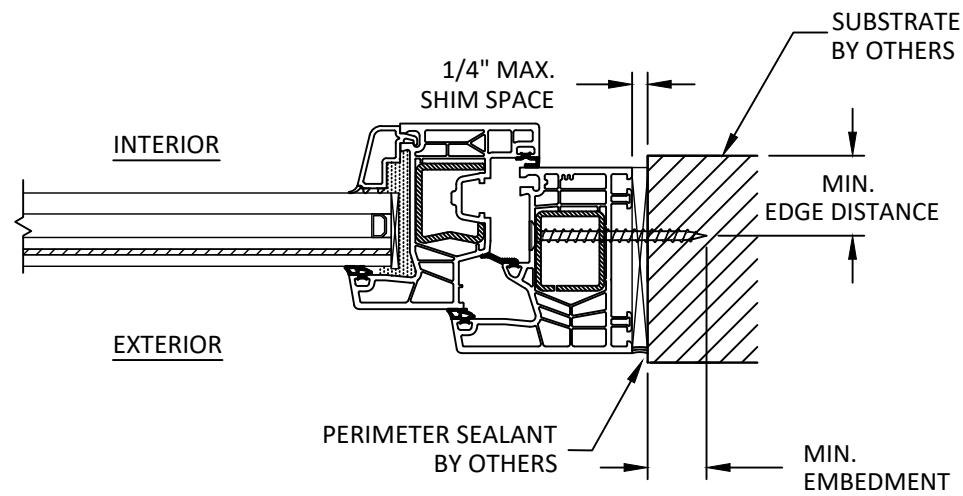

A
6 **HORIZONTAL SECTION**
THROUGH FRAME (JAMB)

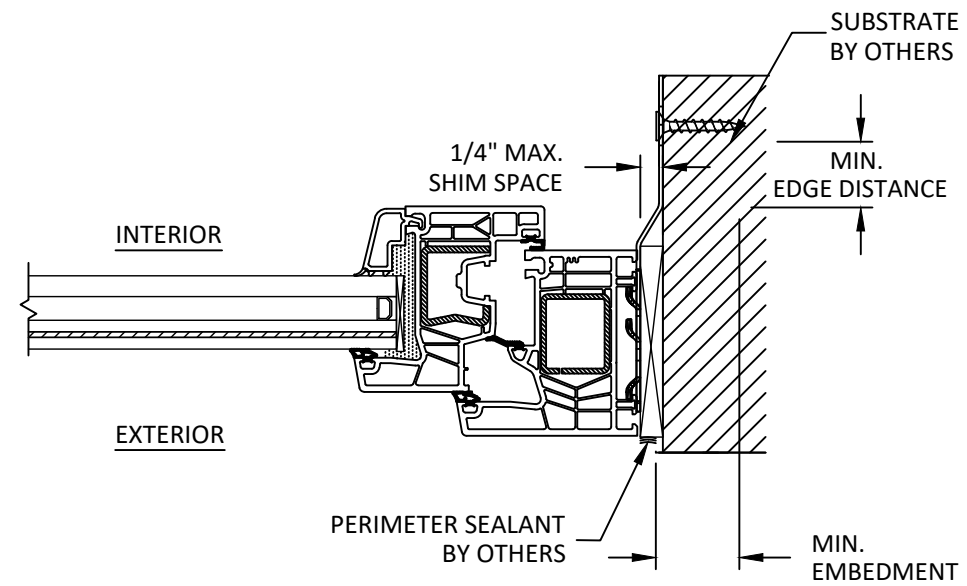

B
6 **HORIZONTAL SECTION**
STRAP (JAMB)

INSTALLATION NOTES:

- ONE (1) INSTALLATION ANCHOR IS REQUIRED AT EACH ANCHOR LOCATION SHOWN.
- THE NUMBER OF INSTALLATION ANCHORS DEPICTED IS THE MINIMUM NUMBER OF ANCHORS TO BE USED FOR PRODUCT INSTALLATION OF THE MAXIMUM SIZE LISTED.
- INSTALL INDIVIDUAL INSTALLATION ANCHORS WITHIN A TOLERANCE OF ±1/4 INCH THE DEPICTED LOCATION & SPACING IN THE ANCHOR LAYOUT DETAILS (I.E., WITHOUT CONSIDERATION OF TOLERANCES). TOLERANCES ARE NOT CUMULATIVE FROM ONE INSTALLATION ANCHOR TO THE NEXT.
- SHIM AS REQUIRED AT EACH INSTALLATION ANCHOR WITH LOAD BEARING SHIM(S). MAXIMUM ALLOWABLE SHIM STACK TO BE 1/4 INCH. SHIM WHERE SPACE OF 1/16 INCH OR GREATER OCCURS. SHIM(S) SHALL BE CONSTRUCTED OF HIGH DENSITY PLASTIC OR BETTER.
- FOR MASONRY OR CONCRETE OPENINGS, A 1X WOOD BUCK MAY BE USED (OPTIONAL) AS LONG AS THE MINIMUM EMBEDMENT AND EDGE DISTANCE REQUIREMENTS ARE STILL MET WITHIN THE CORRESPONDING HOST SUBSTRATE. SEE GENERAL NOTE #3 ON SHEET 1 FOR MORE INFORMATION.
- MINIMUM EMBEDMENT AND EDGE DISTANCE EXCLUDE WALL FINISHES, INCLUDING BUT NOT LIMITED TO STUCCO, FOAM, BRICK VENEER, AND SIDING.
- INSTALLATION ANCHORS AND ASSOCIATED HARDWARE MUST BE MADE OF CORROSION RESISTANT MATERIAL OR HAVE A CORROSION RESISTANT COATING.
- FOR HOLLOW BLOCK AND GROUT FILLED BLOCK, DO NOT INSTALL INSTALLATION ANCHORS INTO MORTAR JOINTS. EDGE DISTANCE IS MEASURED FROM FREE EDGE OF BLOCK OR EDGE OF MORTAR JOINT INTO FACE SHELL OF BLOCK.
- INSTALLATION ANCHORS SHALL BE INSTALLED IN ACCORDANCE WITH ANCHOR MANUFACTURER'S INSTALLATION INSTRUCTIONS, AND ANCHORS SHALL NOT BE USED IN SUBSTRATES WITH STRENGTHS LESS THAN THE MINIMUM STRENGTH SPECIFIED BY THE ANCHOR MANUFACTURER.

ANCHOR SCHEDULE				
METHOD	SUBSTRATE	ANCHOR SCHEDULE	MIN EMBEDMENT	MIN. EDGE DISTANCE
THROUGH FRAME	WOOD: MIN. SG = 0.55	#10 WOOD SCREW FLAT HEAD	1.5"	0.75"
	METAL: 18 GAUGE STEEL, MIN. F _Y = 33KSI	#10 TEK SCREW FLAT HEAD	3 THREADS MIN PENETRATION BEYOND METAL	0.5"
	METAL: ALUMINUM MIN. THICKNESS 1/8". MIN. 6063-T5			
	CONCRETE: MIN. F'C=3000PSI	3/16" ITW TAPCON FLATHEAD	1.25"	2.0
	MASONRY: CMU per ASTM C90 MIN. 2000 PSI	3/16" ITW TAPCON FLATHEAD	1"	2.0



7905 NW 77TH AVE
 MEDLEY, FL 33166
 PH: (305) 888-5718 FX: (305) 220-5073

TITLE: 76MD IN-SWING CASEMENT/TILT & TURN WINDOW (IMPACT) (HVHZ)
INSTALLATION NOTES ANCHOR DETAILS
PREPARED BY: BUILDING DROPS, INC.
 398 E. DANIA BEACH BLVD., STE. 338
 DANIA BEACH, FL 33004
 PH: (954) 399-8478
 FAX: (954) 474-4738
 WEB: www.buildingdrops.com

REMARKS	BY	DATE

THE INSTALLATION DETAILS DESCRIBED HEREIN ARE GENERIC AND MAY NOT REFLECT ACTUAL CONDITIONS FOR A SPECIFIC SITE. IF SITE CONDITIONS CAUSE INSTALLATION TO DEVIATE FROM THE REQUIREMENTS DETAILED HEREIN, A LICENSED ENGINEER OR ARCHITECT SHALL PREPARE SITE SPECIFIC DOCUMENTS FOR USE WITH THIS DOCUMENT



HERMES F. MORERO, P.E.
 LICENSE No. 73778
 STATE OF FLORIDA
 PROFESSIONAL ENGINEER
 398 E. DANIA BEACH BLVD. # 338
 DANIA BEACH, FL 33004
 FBPE CERT. OF AUTHORIZATION No. 29578

FL#: FL29689
DATE: 06.09.19
DWG. BY: EG **CHK. BY:** HFN
SCALE: NTS
DWG. #: ECI013
SHEET: 6 OF 8

s:\projects\eurocraft_industries inc\cc-20-0916-fbc code change (ver. 7)\2-revision due to alum. anchors\129689\dwg\eci013 - in-swing cs.dwg
 12/18/2020 9:11 AM

BILL OF MATERIALS			
IN-SWING			
ITEM	PART No.	DESCRIPTION	MATERIAL
1	76171	FRAME - RIGID VINYL	VINYL
2	2454	I.G. GLAZING BEAD	VINYL
3	2452	MONO GLAZING BEAD	VINYL
4	-	GLAZING GASKET (RUBBER 70 DUR)	EPDM
5	76472	MULLION	VINYL
6	76271	VENT	VINYL
7	V310	REINFORCEMENT	STEEL
8	V308	REINFORCEMENT	STEEL
9	V319	REINFORCEMENT	STEEL
10	76372	FRAME	STEEL
11	V317	REINFORCEMENT	STEEL

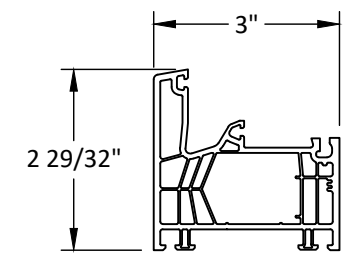
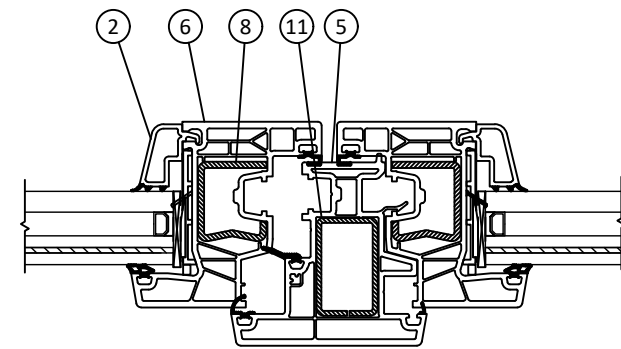
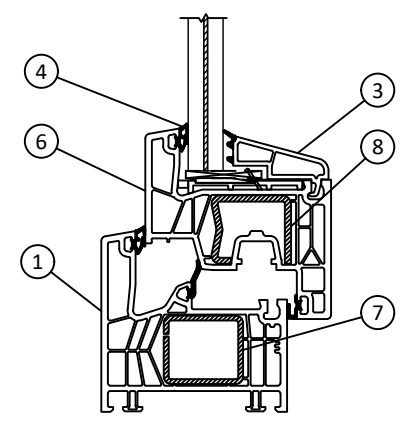
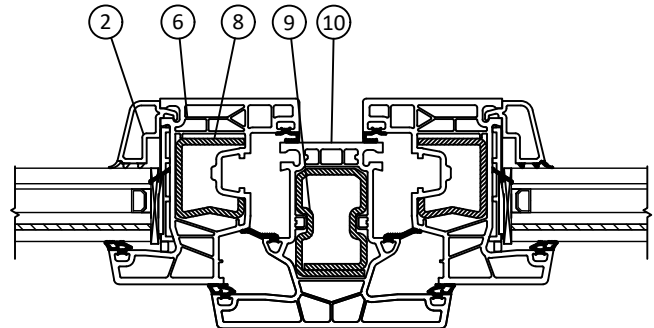

① FRAME

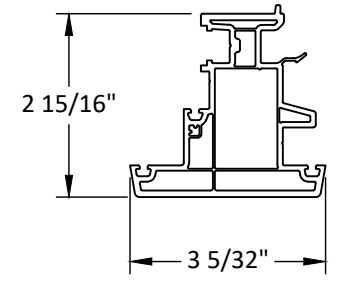

⑤ MULLION

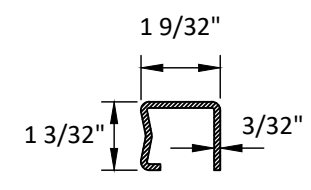

⑧ REINFORCEMENT

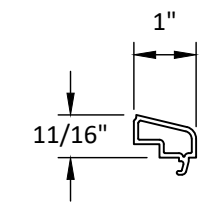

② I.G. GLAZING BEAD

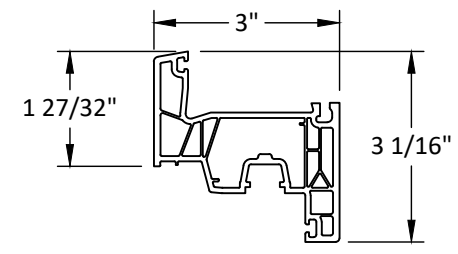

⑥ VENT

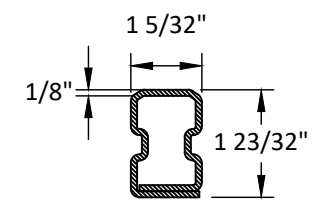

⑨ REINFORCEMENT

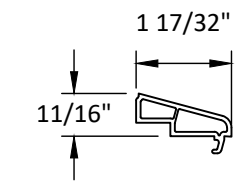

③ LAMI GLAZING BEAD

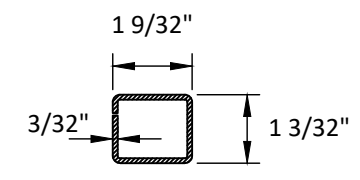

⑦ REINFORCEMENT

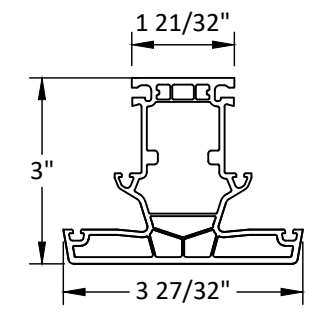

⑩ MULLION

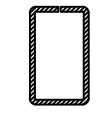

⑪ REINFORCEMENT

Eurocraft
 7905 NW 77TH AVE
 MEDLEY, FL 33166
 PH: (305) 888-5718 FX: (305) 220-5073

TITLE: 76MD IN-SWING CASEMENT/TILT & TURN WINDOW (IMPACT) (HVHZ)
 COMPONENTS & BILL OF MATERIALS
 PREPARED BY:  BUILDING DROPS, INC.
 398 E. DANIA BEACH BLVD., STE. 338
 DANIA BEACH, FL 33004
 PH: (954) 359-8478
 FAX: (954) 474-4738
 WEB: www.buildingdrops.com

REMARKS	BY	DATE

THE INSTALLATION DETAILS DESCRIBED HEREIN ARE GENERIC AND MAY NOT REFLECT ACTUAL CONDITIONS FOR A SPECIFIC SITE. IF SITE CONDITIONS CAUSE INSTALLATION TO DEVIATE FROM THE REQUIREMENTS DETAILED HEREIN, A LICENSED ENGINEER OR ARCHITECT SHALL PREPARE SITE SPECIFIC DOCUMENTS FOR USE WITH THIS DOCUMENT

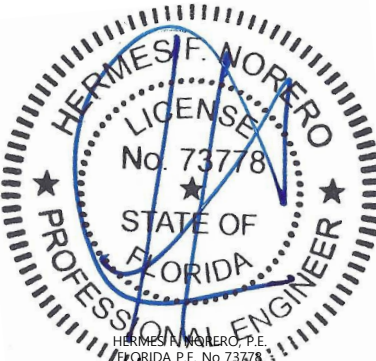
 HERMES F. MORERO, P.E.
 LICENSE No. 73778
 STATE OF FLORIDA
 PROFESSIONAL ENGINEER
 398 E. DANIA BEACH BLVD. # 338
 DANIA BEACH, FL 33004
 FBPE CERT. OF AUTHORIZATION No. 29578

FL#: **FL29689**
 DATE: **06.09.19**
 DWG. BY: **EG** CHK. BY: **HFN**
 SCALE: **NTS**
 DWG. #: **ECI013**
 SHEET: **7** OF 8

MULTIPOINT HARDWARE

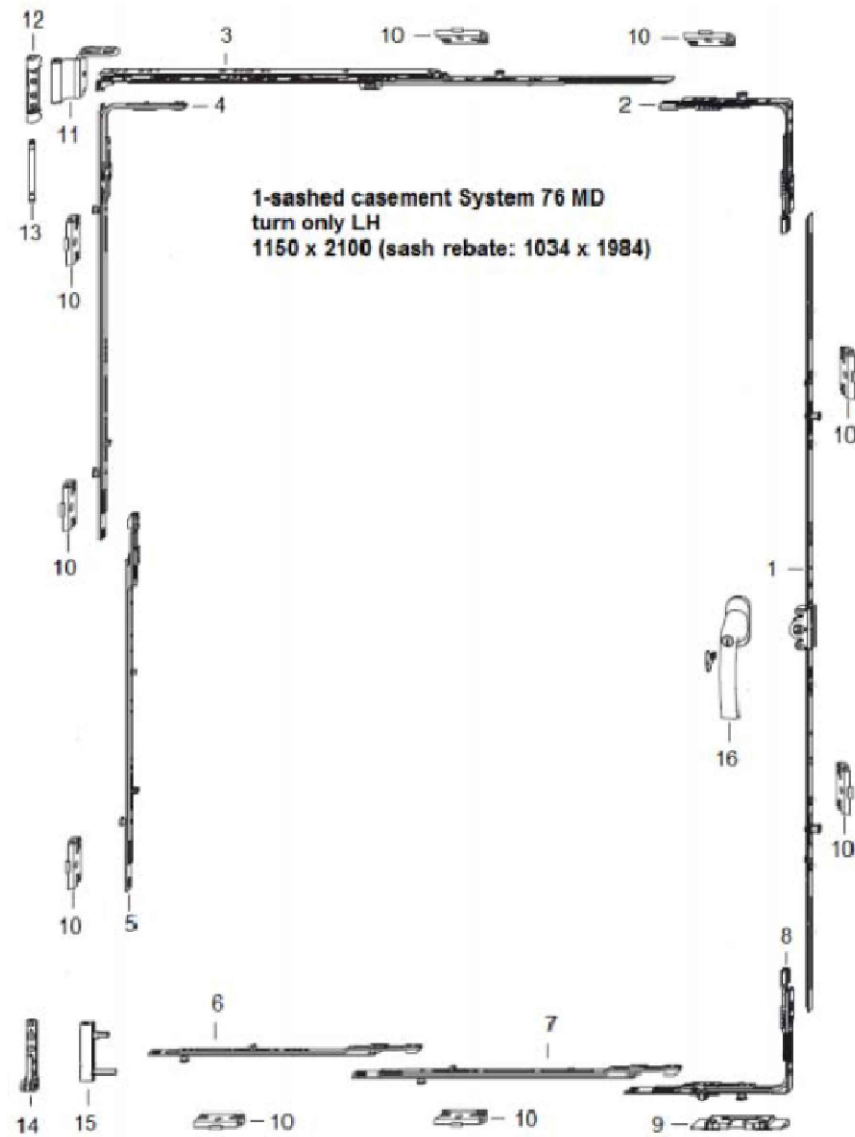

Pos.	part description	part code
1	gear 15 AF sz.160 2RS 70	TGMK4170-...
2	corner drive AF VSO 1RS	TEUL4010-...
3	stay AF sz.3 1RS	TSKK2030-...
4	corn.drive BS/K3 sz 2+ 2RS	TEUL2390-...
5	linkage BS/FH sz 3+ 1RS	TZBS0300-...
6	extension sz 3+ 1RS	TVSL0330-...
7	linkage BS/FH sz 1+ 1RS	TZBS0180-...
8	corn.drive AF VSU/K+ FH 1S	TEUL5010-...
9	tilt lock bearing S-ES FH A4460	FRKA0100-...
10	striker plate S-RS 3SL A4460	TRSK0600-...
11	stay hinge 12/20-13 DH	TBWB6050-...
12	top hinge KF D6x24 DH	TBSL6140-...
13	top hinge pin poly	TBSB6020-...
14	bottom hinge KF D6x3/24	TBEL6120-...
15	corner hinge KF D6x16/36 D5 ADV	TBEB6140-...
16	handle Globe 35/12 ABS100 SEC	ZHGA0060-...



7905 NW 77TH AVE
MEDLEY, FL 33166
PH: (305) 888-5718 FX: (305) 220-5073

TITLE:
76MD IN-SWING CASEMENT/TILT
& TURN WINDOW(IMPACT) (HVHZ)

MULTIPOINT HARDWARE

PREPARED BY:

BUILDING DROPS, INC.
398 E. DANIA BEACH BLVD., STE. 338
DANIA BEACH, FL 33004
PH: (954)399-8478
FAX: (954)744-4738
WEB: www.buildingdrops.com



REMARKS	BY	DATE

THE INSTALLATION DETAILS DESCRIBED HEREIN ARE GENERIC AND MAY NOT REFLECT ACTUAL CONDITIONS FOR A SPECIFIC SITE. IF SITE CONDITIONS CAUSE INSTALLATION TO DEVIATE FROM THE REQUIREMENTS DETAILED HEREIN, A LICENSED ENGINEER OR ARCHITECT SHALL PREPARE SITE SPECIFIC DOCUMENTS FOR USE WITH THIS DOCUMENT

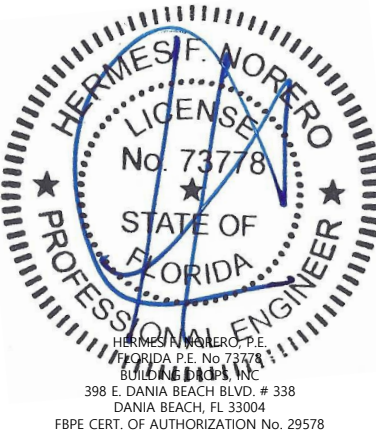

FL#:	FL29689
DATE:	06.09.19
DWG. BY:	EG
CHK. BY:	HFN
SCALE:	NTS
DWG. #:	ECI013
SHEET:	8